

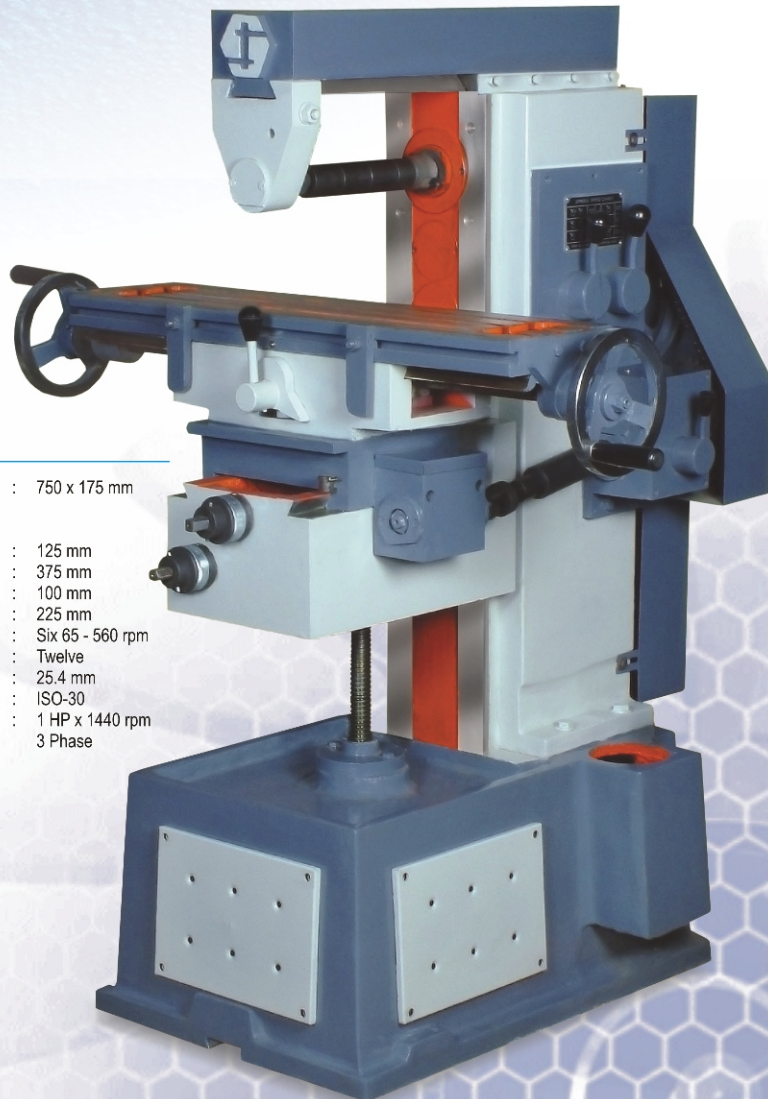

SUNRISE

UNIVERSAL GEAR HEAD MILLING MACHINE No.0A



Specification

Working Surface	: 750 x 175 mm
Distance from Spindle centre to underside of over support	: 125 mm
Longitudinal feed	: 375 mm
Cross feed	: 100 mm
Vertical feed	: 225 mm
Spindle Speed	: Six 65 - 560 rpm
Number of feed	: Twelve
Arbour	: 25.4 mm
Spindle Bore	: ISO-30
Electric Motor	: 1 HP x 1440 rpm 3 Phase

UNIVERSAL GEAR HEAD MILLING MACHINE No. 2

Specification

- Working Surface : 1050 x 250 mm
- Distance from Spindle centre to underside of over support : 125 mm
- Longitudinal feed : 600 mm
- Cross feed : 230 mm
- Vertical feed : 450 mm
- Spindle Speed : 65 - 725 rpm
- Number of feed : Three
- Arbour : 25.4 mm
- Spindle Bore : ISO-40
- Electric Motor : 2 HP x 1440 rpm
3 Phase

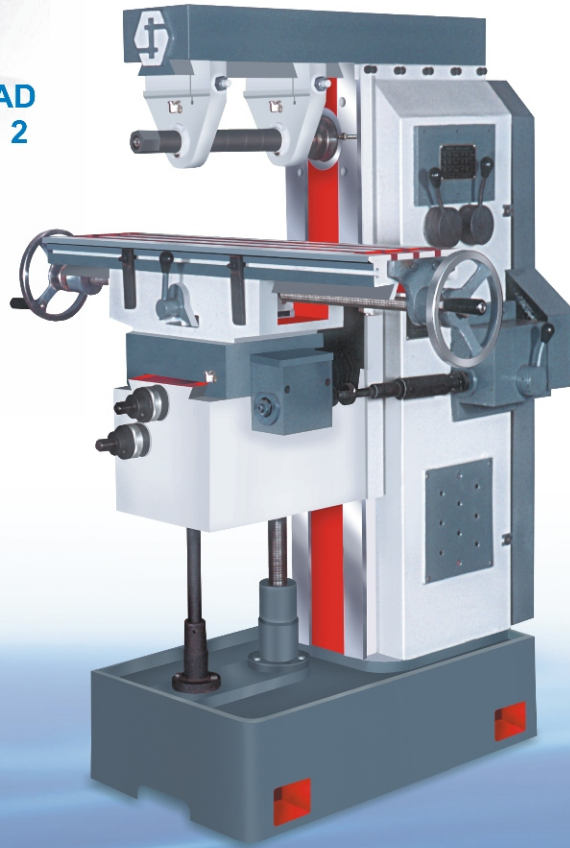

SLOTING MACHINE

Specification

- Working Stroke : 150 mm
- Max. Diameter Accommodated : 350 mm
- Longitude Traverse : 75 mm
- Surface Table Size : 290 x 290 mm
- Cross Traverse : 100 mm Table
- Electric Motor : 1 HP x 1440 rpm
3 Phase

DEALER :

MANUFACTURER
SUNRISE INDUSTRIES - RAJKOT

Radhika : 98240 90963